

ECO-HYBRID COMPOSITE FAILURE BEHAVIOR OF TWO SERIAL BOLTED JOINT HOLES

D. Sivakumar^{1,2*}, L.F. Ng¹, N.S. Salmi¹

¹Faculty of Mechanical Engineering, Universiti Teknikal Malaysia Melaka,
Hang Tuah Jaya, 76100 Durian Tunggal, Melaka, Malaysia.

²Center for Advanced Research on Energy, Universiti Teknikal Malaysia Melaka,
Hang Tuah Jaya, 76100 Durian Tunggal, Melaka, Malaysia.

ABSTRACT

This study investigates the geometrical effect of two serial bolted joint holes on hybrid composites. Geometry parameters studied were edge distance-to-upper hole centre (E/D) and the distance between centers of two holes diameter (K/D). The hybrid composites were fabricated using kenaf woven fiber and E-glass woven fiber. Composite specimens were manufactured through hot press molding compression method at 180°C. The bearing test was conducted according to ASTM D-5961 'Procedure C'. The results show bearing strength and failure mechanisms of hybrid composites highly depend on the geometry parameters. Hybrid composites with the highest geometrical parameter, K/D = 5 and E/D = 4, show the highest bearing strength (32.381 MPa) while hybrid composites with the lowest geometrical parameter, K/D = 2 and E/D = 2, exhibit the lowest bearing strength (20.445 MPa). Therefore, this indicates that bearing strength increases with increase of K/D and E/D ratio. The failure behaviors observed were shear-out modes, bearing modes and net-tension modes.

KEYWORDS: Bolted joint; thermoplastic; woven kenaf fiber; hybrid composites

1.0 INTRODUCTION

Fiber-reinforced composites are a well-known material in industries. They have been widely used in aircraft and space structural applications since they have a high specific modulus, high specific strength, low density and long fatigue life (Karakuzu, Taylak, İçten, & Akta, 2008a; Ozen & Sayman, 2011; Soykok, Sayman, Ozen & Korkmaz, 2013a). Composites are not only used in aviation; they are also used in military and commercial air vehicles, robot arms, and the automotive industry (Soykok, Sayman & Pasinli, 2013b).

Generally, mechanical fasteners like bolts, rivets and pin-connectors are utilized for composites assembly purposes. The main reason for using mechanical fasteners is because they can be assembled and disassembled easily, low cost and simplicity (Pisano, Fuschi & De Dominicco, 2012). Many studies have been conducted to identify the effect of mechanical fasteners on the behavior of the composites. Pisano *et al.* (2012) used experimental and numerical findings to determine the effect of the pinned joint on composite laminates. Khashaba, Sebaey and Alnefaie (2013) studied the effect of stacking sequences on the failure and reliability of pinned-joint composite laminates.

* Corresponding Email: sivakumard@utem.edu.my

Stress concentration is the main challenge when a mechanical fastener is used in composite joints. The load distributions in the mechanically fastened joints depend on the number, size, and the bolt material itself (Ozen & Sayman, 2011). Thus, the mechanical fastener may cause failure of the composites. The typical failure modes are illustrated in Figure 1(a-c): net-tension mode, shear-out mode and bearing failure. Meanwhile, Figure 1(d-e) show the combination of the failure modes (Pisano et al., 2012).

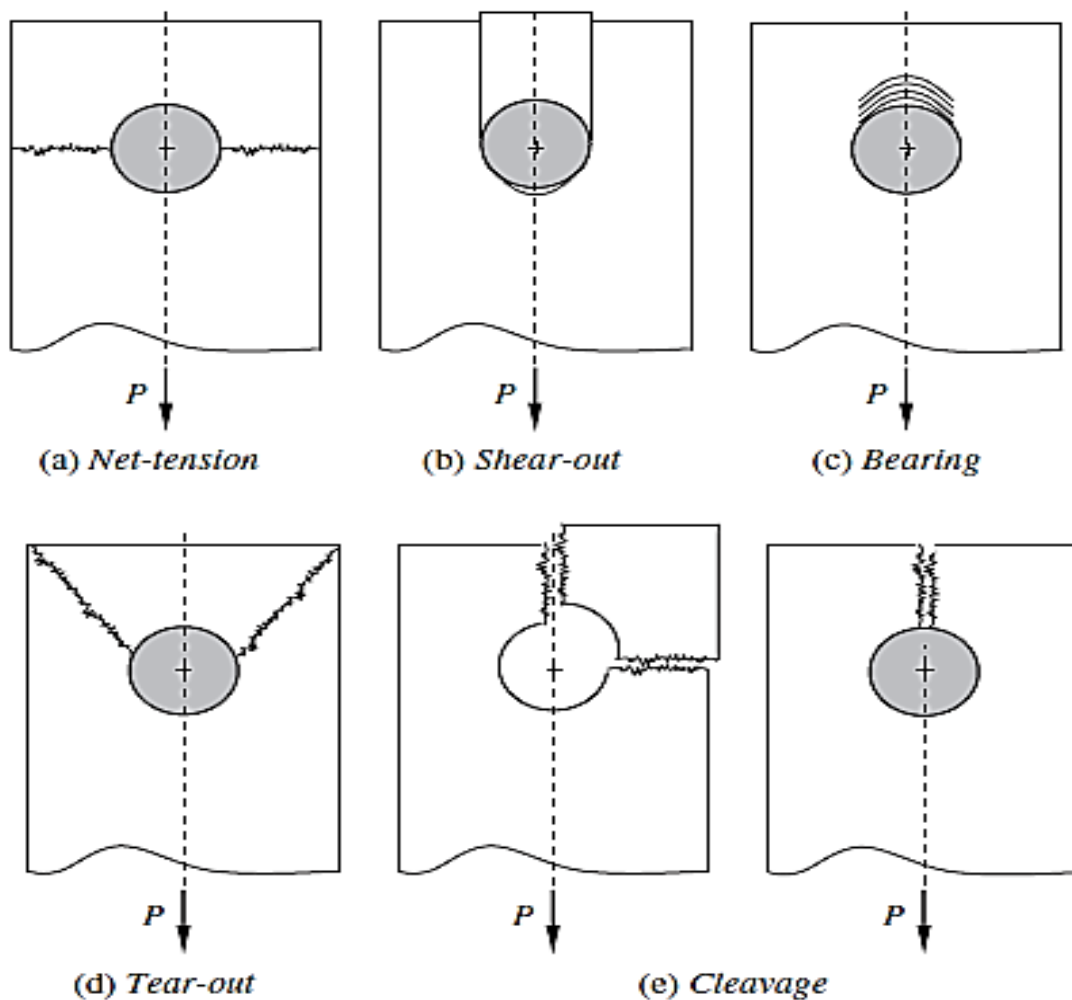

Figure 1. The sketch of typical failure modes Cleavage (Pisano et al., 2012)

Natural fibers have many significant advantages over synthetic fibers. Previous research has shown that these advantages include the former's low density, low cost, recyclability and biodegradability. These advantages make natural fibers a potential reinforcement to replace glass fibers in composite materials. Mechanical properties of natural fibers are excellent and may compete with glass fiber in terms of specific strength and modulus (Li, Tabil & Panigrahi, 2007). Natural fiber-reinforced composites can be applied in the plastics, automobile (Dharmalingam, Compston & Kalyanasundaram, 2009) and packaging industries to reduce overall material cost.

Kenaf, *Hibiscus cannabinus*, a member of the hibiscus family is a biodegradable and environmentally friendly crop. It has been found to be an important source of fiber for

composites and other industrial applications. The fiber is fully biodegradable, non-toxic and recyclable. Based on the study conducted by Abdul Khalil, Yusra, Bhat and Jawaaid (2010), kenaf in Malaysia is composed of two distinct fibers, bast and core, with a make-up of about 35% and 65%, respectively. These two different fibers have their own specific applications. Thus, separation of the fibers produces higher monetary returns over whole-stalk kenaf. The main consideration involved in the separation of kenaf into its two parts include size and amount of each portion, type and amount of separation machinery, processing rate through separation machinery, moisture content of whole-stalk kenaf and humidity of ambient air (Abdul Khalil et al., 2010).

Fiber reinforced composites consist of fiber as reinforcement and a polymer as a matrix. Natural fiber composites such as hemp fiber-epoxy, flax fiber-polypropylene (PP) and China reed fiber-PP are commonly used in automotive applications since natural fiber has low-cost and low-density characteristics which are 35% to 40% lower than glass fiber (Joshi, Drzal, Mohanty & Arora, 2004). This pioneering study aimed to investigate the behavior of woven kenaf-glass hybrid composites under the two serial bolted joint hole bearing test. The geometrical ratios studied were edge distance-to-upper hole centre (E/D) and the distance between centers of two holes diameter (K/D).

2.0 METHODOLOGY

2.1 Sample Preparation

The composites panel consists of three layers of woven fiber stacked in the sequence of woven glass fiber/woven kenaf fiber/woven glass fiber in a polypropylene (PP) matrix. A composites panel with nominal 3 mm thickness was manufactured through the hot press molding compression method. The woven fiber stacks and PP were placed in a picture frame mold with dimensions of $250 \times 170 \times 3$ mm (length \times width \times thickness). Then, the picture frame mold was placed in the hot press machine at 180 C for five minutes. After that, pressure was increased gradually to 30 kg/cm^2 for another four minutes. The composites was allowed to cool to room temperature before being removed from the picture frame mold.

Table 1. Double-shear and single-shear one-piece test specimen dimensions

Parameter	Standard Dimension, mm
Fastener or pin diameter, d	$6 + 0.00/-0.03$
Hole diameter, D	$6 + 0.03/-0.00$
Thickness, t	3-5
Length, L	135
Width, W	36 ± 1

Figure 2 shows the schematic drawing of the standard specimen used in the bearing test according to ASTM D-5961, whilst Table 1 shows its detailed dimensions. The specimens were cut and drilled into the desired dimensions by using a Proxxon table saw and drilling machine.

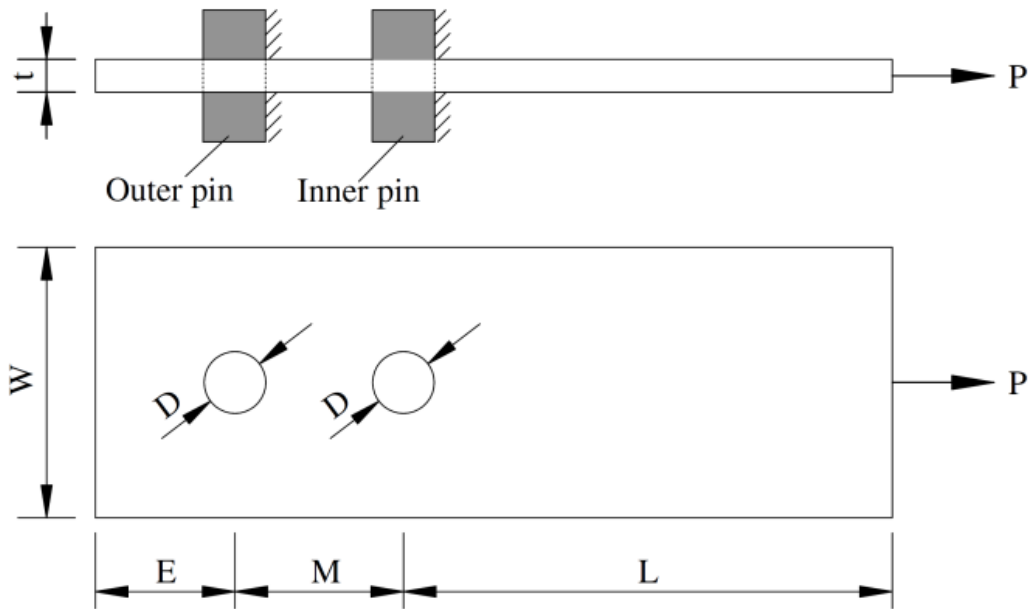

Figure 2. The standard specimen based on ASTM D5961 (Karakuzu et al., 2008b)

2.2 Testing

The bearing test was conducted at room temperature by clamping the specimen using the jig, as shown in Figure 3. A distance of 3 cm from the bottom of the specimen is reserved for the clamping zone. The tensile force is applied to the jig with a crosshead displacement rate of 2 mm/min as recommended by Song et al. (2008). The experiment is stopped when the load drops 30% from the maximum load as recommended in the ASTM standard.

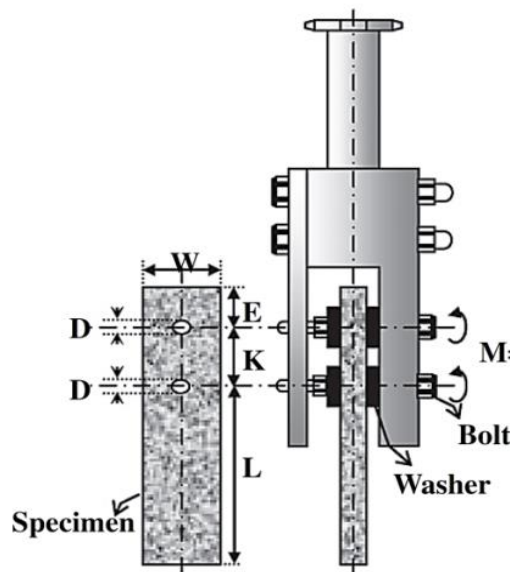

Figure 3. The bearing test set-up (Ozen & Sayman, 2011)

3.0 RESULTS AND DISCUSSION

The failure loads and failure modes of woven kenaf-glass hybrid composite specimens with two serial holes which are subjected to tensile force are investigated. Three tests were conducted for each geometrical parameter and the average readings were calculated. Figure 4 illustrates the average load-displacement diagram for the bearing test of the hybrid composites with different geometrical parameters. All load-displacement curves have a linear relationship regardless of the K/D and E/D ratio. Linear relationship was observed up to a point where the deviation of linearity occurs. Nonlinearity of the curve is because of the progressive debonding between matrix and reinforcement. As seen in Figure 4, the load-bearing capacity of the hybrid composites gradually reduces when E/D ratio decreases. This can be attributed to the small edge-to-hole distance, which results in catastrophic shear-out failure mode due to excessive tensile and shear stress. Figure 5 shows the maximum average failure load for E/D ratio = 2, 3 and 4 and K/D ratio = 2, 3, 4 and 5.

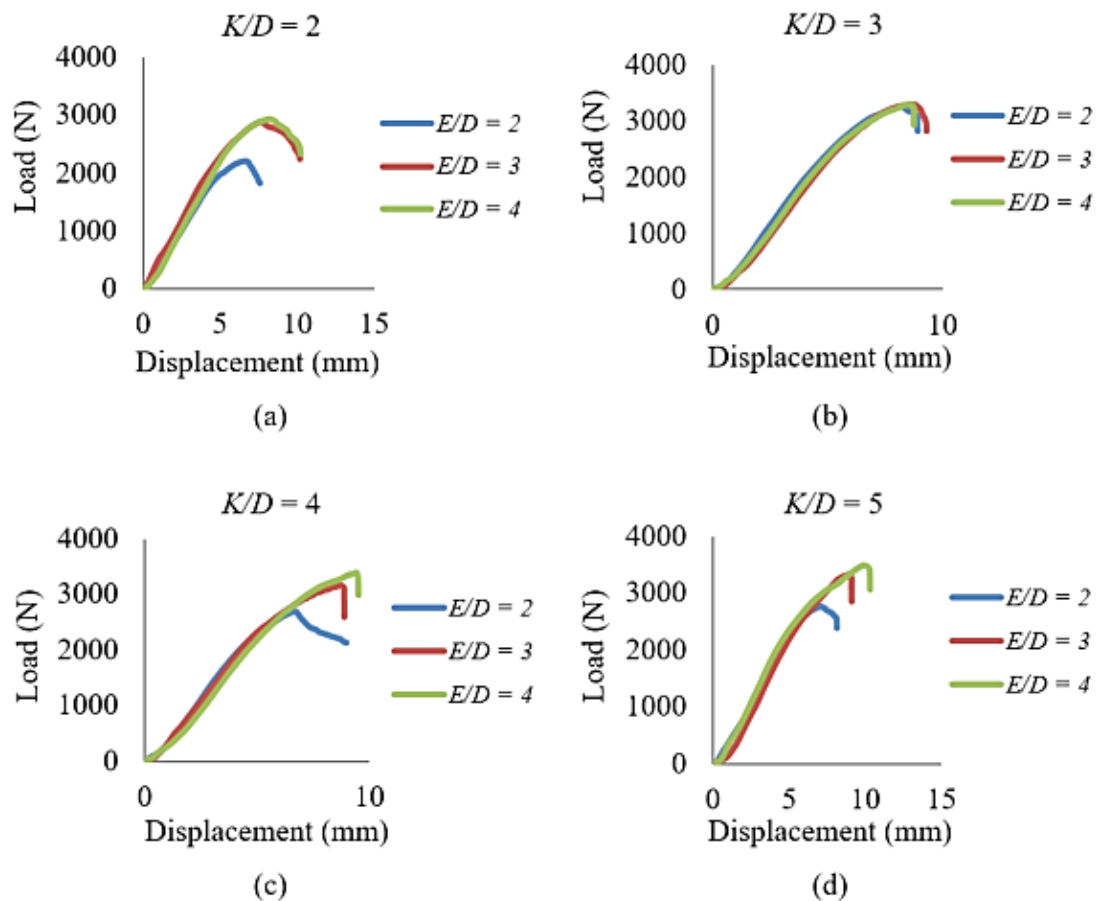

Figure 4. Load displacement diagram of a two serial bolted joint holes with different geometrical parameters

Based on Figure 5, maximum load increases with E/D ratio and K/D ratio except for the case of $K/D = 3$ and $E/D = 2$ and 3 . When the $E/D=4$ and $K/D=5$, the maximum load is the highest at 3497 N. For $E/D=2$, the maximum failure load readings are the lowest compared to other E/D ratios. This is because, when the E/D ratio is 2, it is easier for the composites to have a shear-out mode, as a small E/D ratio reduces the composite's bearing strength. The different failure mechanisms for the bearing test are shown in Figure 6. Failure mechanisms are mainly affected by the different geometrical parameters. From Figure 6, it can be seen that net-tension failure mode occurred only when K/D was high enough while shear-out failure mode was observed only when E/D was small enough. The inner hole of every specimen showed bearing failure mode regardless of the E/D and K/D ratio.

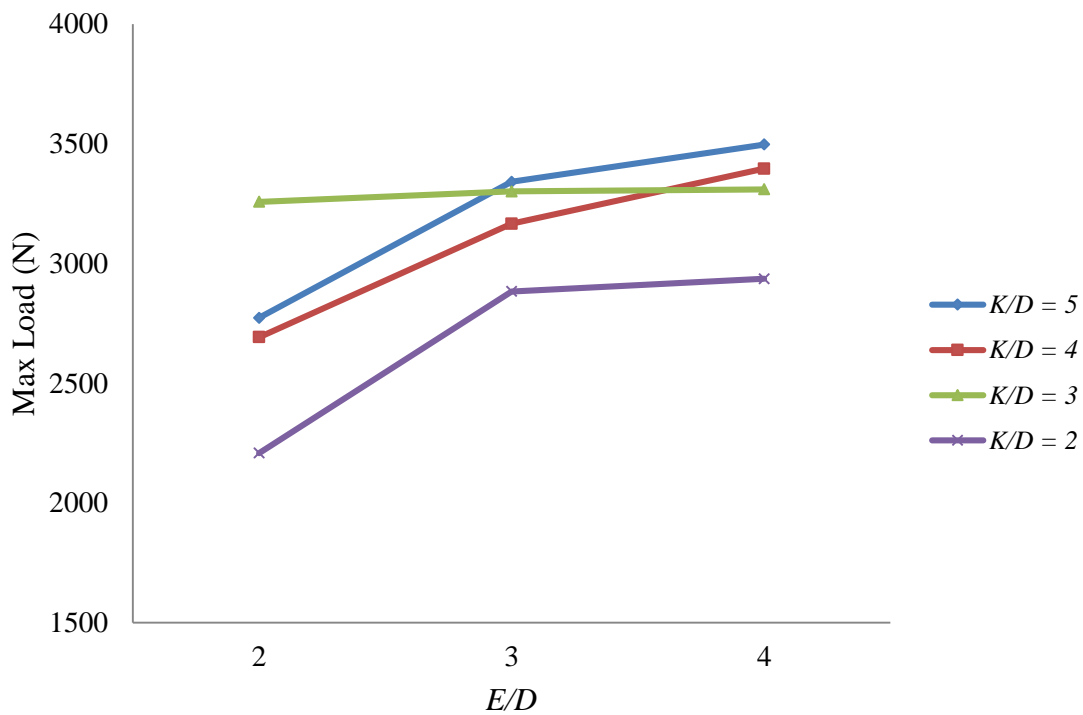

Figure 5. Maximum failure load in experimental studies for different geometrical parameters

Table 2 summarizes the failure modes. The mixed modes of bearing and net tension are formed at the inner holes when K/D ratios are fixed at 3 and 5, except for the case of $K/D = 4$ and $E/D = 4$. For $K/D = 2$, inner holes and outer holes experience full bearing mode regardless of E/D ratio. Bearing failure mode was also observed at outer holes of the specimens when $K/D > 2$ and $E/D = 3$ and 4 . Shear-out failure mode was only observed at outer holes of the composites when $E/D = 2$. This is due to the small distance between the edge and the hole, resulting in shear stress developing in the shear-out plane around the hole in the axial direction. Karakuzu et al. (2008) reported that bearing failure modes are commonly found in engineering applications. The most common failure mechanisms that occurred during this study were net tension, shear out and bearing.

Table 2. Failure modes of woven glass-kenaf-glass fiber composites specimen inner hole/outer hole. (B- Bearing mode; N-Net-tension mode and S-Shear out mode)

		<i>K/D</i>			
		2	3	4	5
<i>E/D</i>	2	B/B	B+N/S	B/S	B+N/S
	3	B/B	B+N/B	B/B	B+N/B
	4	B/B	B+N/B	B+N/B	B+N/B

From Table 2, it can be concluded that, for the inner hole, the net-tension mode depends on K/D ; it starts to form when $K/D = 3$ and 5; while the bearing mode starts to form at the outer hole when $E/D > 2$, except for the cases of $K/D = 2$ and $E/D = 2$. Increasing the E/D ratio changes the failure mode from shear-out mode to bearing mode. Meanwhile, increasing the K/D ratio changes the failure mode from bearing to net tension. However, the shear-out mode commonly happened at the outer hole for the lowest E/D , whereas bearing mode failure mostly happened at the outer hole for greater E/D .

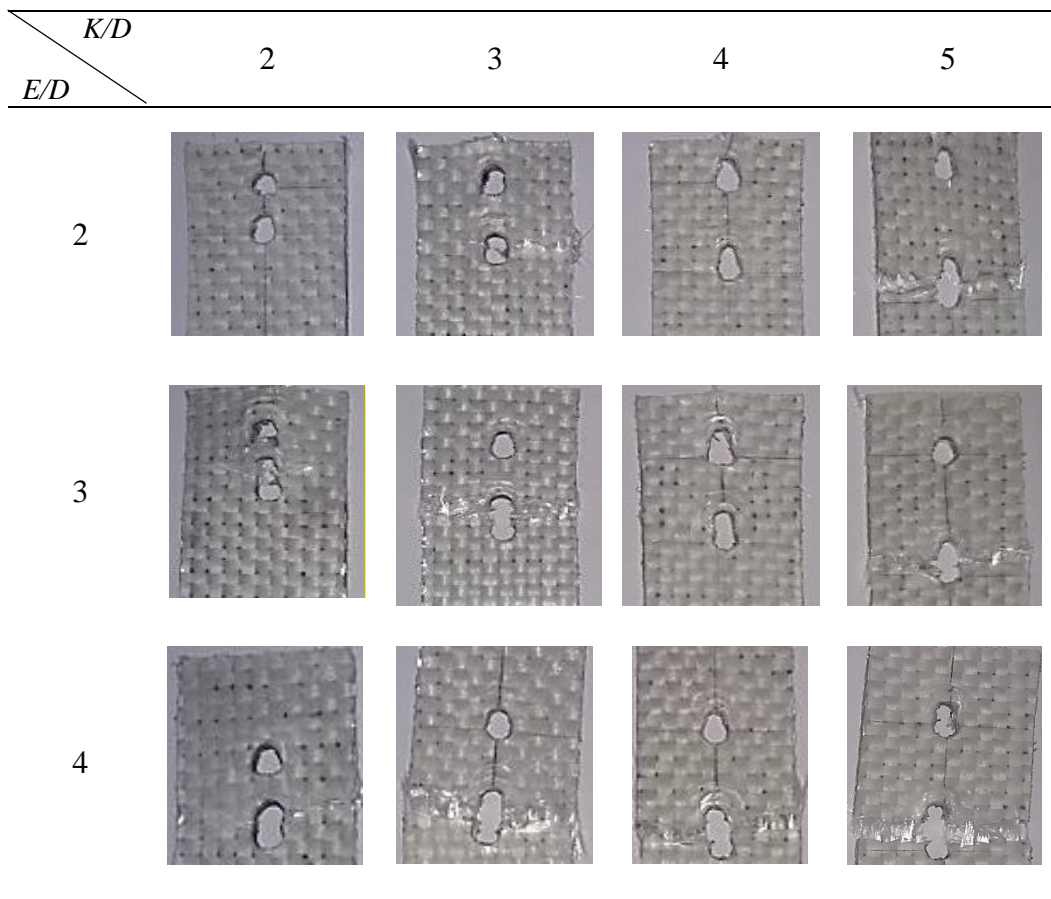

Figure 6. Various failure modes from experimental studies for $E/D=2$ to 4 and $K/D=2$ to 5

Figure 7 represents the typical bearing strength for different E/D and K/D ratios. The bearing strength, σ_b , of the specimen can be represented as Equation (1):

$$\sigma_b = \frac{P}{tD} \tag{1}$$

where P is the failure load, t is the thickness of the specimen and D is the diameter of the circular hole (Karakuzu et al., 2006; Ozen & Sayman, 2011).

In Figure 7, the smallest K/D gives the lowest bearing strength reading, which indicates the lowest failure load exhibited in the specimens. $K/D= 2$ to 5 show the increment of bearing strength with increase of E/D ratio. From Figure 7, $E/D = 4$ and $K/D = 5$ show the maximum bearing strength value at 32.381MPa.

Figure 8 shows the box plots for tensile stress for the $E/D = 2$ to 4 and $K/D = 2$ to 5. Most of the reading shows that the failure loads display small range. Therefore, this trend shows deviations of the results are in an acceptable range.

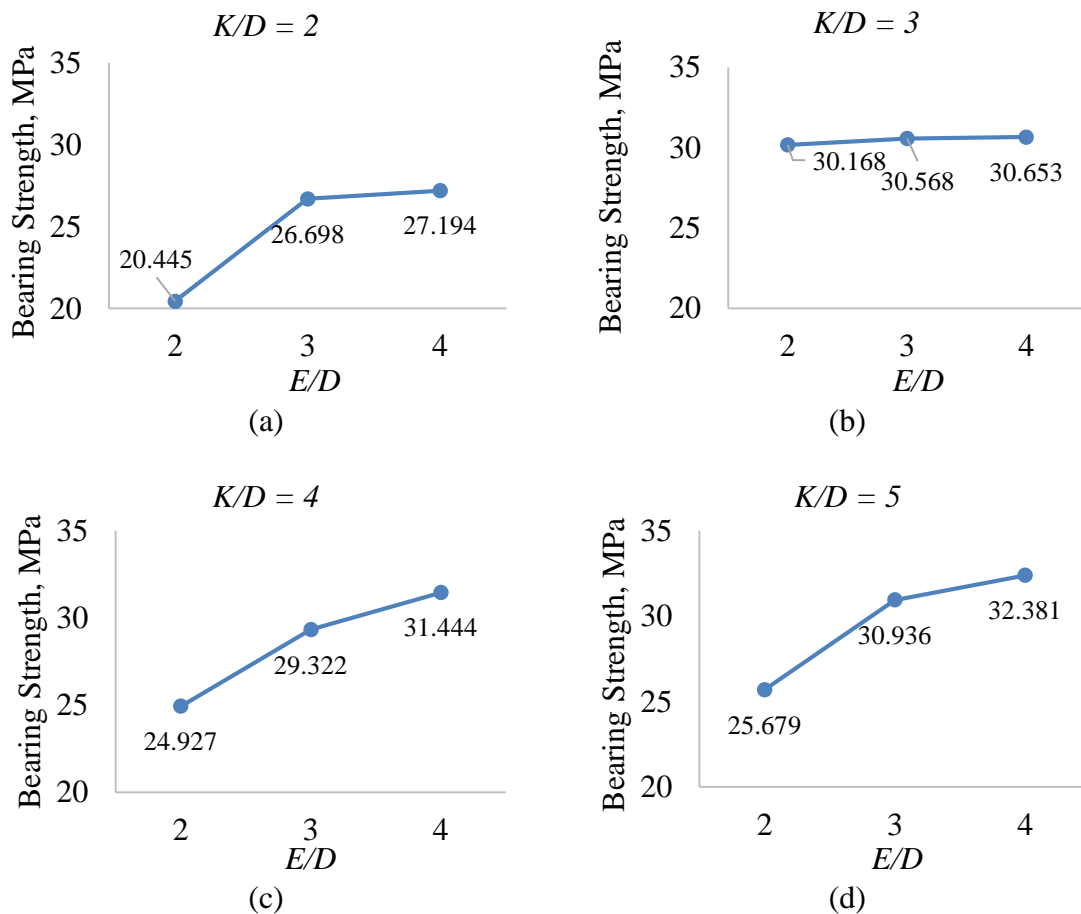

Figure 7. Effect of E/D on bearing strength with various K/D :
 (a) $K/D = 2$ (b) $K/D = 3$ (c) $K/D = 4$ (d) $K/D = 5$

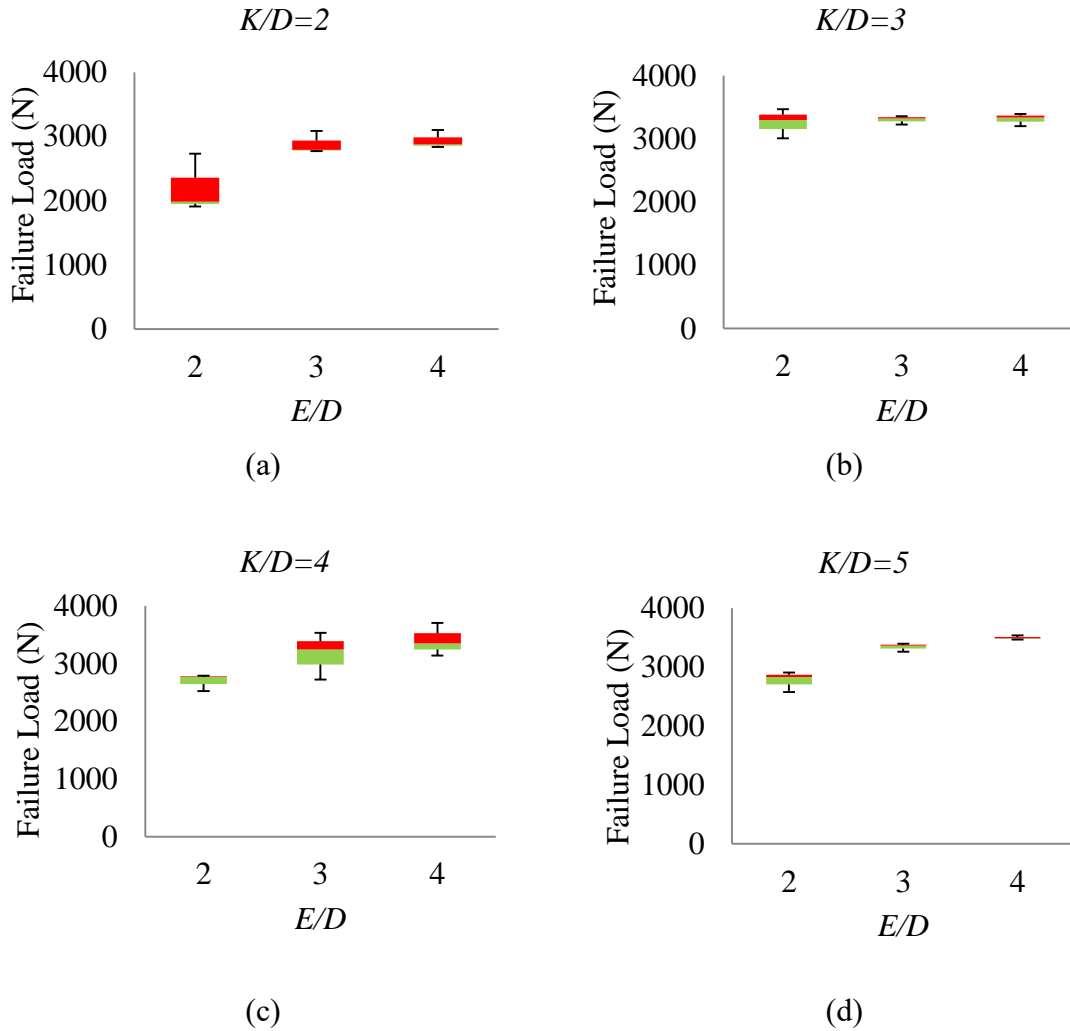

Figure 8. Box plot of failure loads for all K/D and E/D

4.0 CONCLUSION

In this study, the failure modes and the bearing strength of a woven kenaf-glass hybrid composite structure with two serial circular holes were investigated through a bearing test according to ASTM D-5961 ‘Procedure C’. The E/D and K/D ratios were found to have a significant effect on the bearing strength of the hybrid composites.

There are several conclusions that can be made after the results have been evaluated and analyzed. They are:

- i. The larger the ratio of E/D and K/D , the larger the bearing strength obtained. As shown in the result, $K/D=5$ and $E/D=4$ has the largest maximum bearing strength compared to the others;
- ii. E/D and K/D ratios have a significant effect on the failure mechanism of the hybrid composites. A mixed failure mode of bearing and net tension was observed when $K/D=3$ and 5. It has been identified that the mixed mode or bearing failure mode is the most convenient failure mode as it allows larger damage accumulation.

- iii. The failure mode at the outer hole stabilizes when $E/D > 2$. The bearing mode is formed when the edge-to-hole distance increases.

ACKNOWLEDGEMENT

The authors would like to thank Universiti Teknikal Malaysia Melaka for the continuous support of this research project. They also wish to express their gratitude to Lembaga Kenaf dan Tembakau Negara for the sponsorship of kenaf fiber and FRGS/1/2015/SG06/FKM/03/F00276 from the Ministry of Higher Education Malaysia.

REFERENCES

- Abdul Khalil, H.P.S., Yusra, A.F.I., Bhat, A.H. & Jawaid, M. (2010). Cell wall ultrastructure, anatomy, lignin distribution, and chemical composition of Malaysian cultivated kenaf fiber. *Industrial Crops and Products*, 31(1):113–121.
- ASTM D5961/D5961M. (2013). Standard test method for bearing response of polymer matrix composite laminates, PA, USA: ASTM International.
- DharMalingam, S., Compston, P. & Kalyanasundaram, S. (2009). Process variables optimisation of polypropylene based fibre-metal laminates forming using finite element Analysis. *Key Engineering Materials*, 410-411:263–269.
- Joshi, S., V, Drzal, L.T., Mohanty, A.K. & Arora, S. (2004). Are natural fiber composites environmentally superior to glass fiber reinforced composites? *Composites Part A: Applied Science and Manufacturing*, 35(3):371–376.
- Karakuzu, R., Taylak, N., İçten, B.M. & Aktaş, M. (2008a). Effects of geometric parameters on failure behavior in laminated composite plates with two parallel pin-loaded holes. *Composite Structures*, 85(1):1–9.
- Karakuzu, R., Çalışkan, C.R., Aktaş, M. & İçten, B.M. (2008b). Failure behavior of laminated composite plates with two serial pin-loaded holes. *Composite Structures*, 82(2):225–234.
- Khashaba, U.A., Sebaey, T.A. & Alnefaie, K.A. (2013). Failure and reliability analysis of pinned-joints composite laminates: Effects of stacking sequences. *Composites Part B: Engineering*, 45:1694-1703.
- Li, X., Tabil, L.G. & Panigrahi, S. (2007). Chemical treatments of natural fiber for use in natural fiber-reinforced composites: A review. *Journal of Polymers and the Environment*, 15(1):25–33.
- Ozen, M. & Sayman, O. (2011). Failure loads of mechanical fastened pinned and bolted composite joints with two serial holes. *Composites Part B: Engineering*, 42(2):264–274.
- Pisano, A.A., Fuschi, P. & De Domenico, D. (2012). A layered limit analysis of pinned-joints composite laminates: Numerical versus experimental findings. *Composites Part B: Engineering*, 43(3):940–952.

- Song, M.H., Kweon, J.H., Kim, S.K., Kim, C., Lee, T.J., Choi, S.M. & Seong, M.S. (2008). An experimental study on the failure of carbon/epoxy single lap riveted joints after thermal exposure. *Composite Structures*, 86:125–134.
- Soykok, I.F., Sayman, O., Ozen, M. & Korkmaz, B. (2013a). Failure analysis of mechanically fastened glass fiber/epoxy composite joints under thermal effects. *Composites Part B: Engineering*, 45(1):192–199.
- Soykok, I.F., Sayman, O. & Pasinli, A. (2013b). Effects of hot water aging on failure behavior of mechanically fastened glass fiber/epoxy composite joints. *Composites Part B: Engineering*, 54(1):59–70.